

Home Care for Your Wound Drain

When you go home after surgery, you may have one or more drains in place to help your wounds heal. **Hemovac, Jackson Pratt (JP) and Blake** are common drains used for wounds.

The drain has a squeezable container connected to flexible tubing. The tubing is put into an area near your surgical incision. It is held in place by stitches. When the drain is pressed flat, a gentle suction helps remove fluid from the wound. Your doctor will tell you when your drain can be removed.

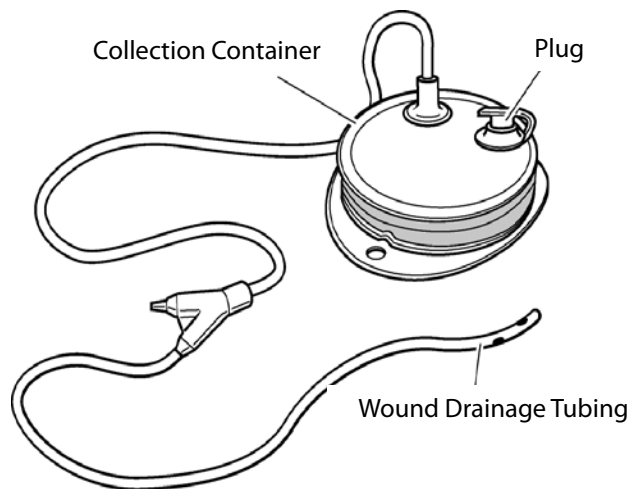

Daryeelka Guriga ee Gororiyaha Nabarkaaga

Marka aad tagtid guriga qalitaanka, waxa laga yaabaa inuu kugu jiro hal gororiye ama ka badan si ay nabaradaada uga caawiyaan bogsashada.

Hemovac, Jackson Pratt (JP) iyo Blake waa gororiyeyaal dhaawac oo caan ah oo loo isticmaalo nabarada.

Gororiyuhu wuxu leeyahay weel la tuujin karo oo ku xidhan tuubo jilicsan. Tuubada waxa la galiyaa meel u dhow barta jeexista lagu sameeyay. Waxa xejinaya tolmooyin. Marka gororiyaha la wada tuujiyo ama la tuujinta loo dhammeeyo, nuugis aayar ah ayaa dheecaanka ka kaxeysa nabarka. Dhakhtarkaaga ayaa kuu sheegi doona goorta lagaa saari doono gororiyaha

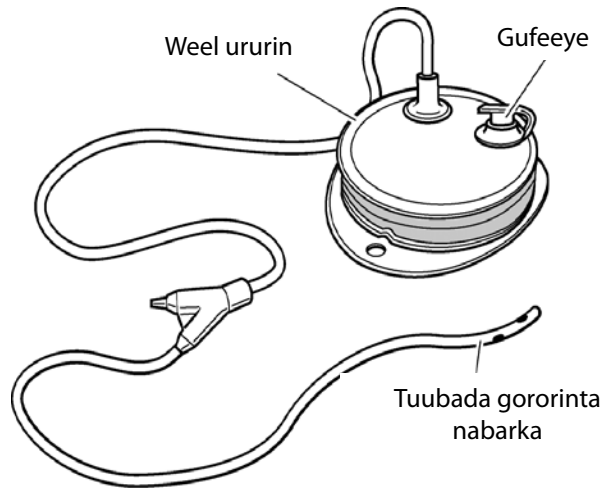

Taking Care of Your Drain(s)

- You must “strip” the drain tubing to clear clots or clogs to keep the drain working right.
- You will need to empty the drain and clean the skin around your drain tubing.
- If your drain has a dressing, you will be given directions about how to change it.

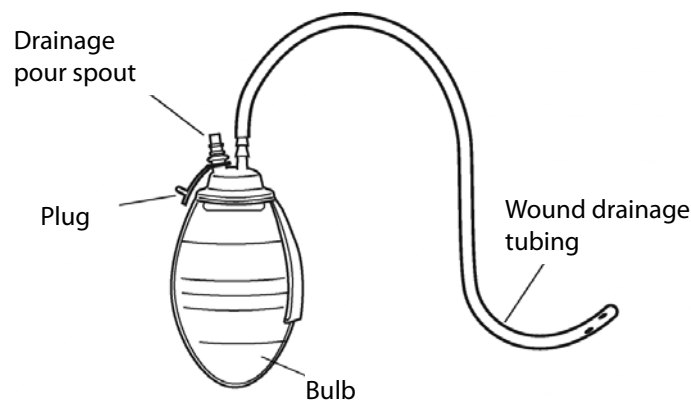

How to “Strip” the Drain Tubing

The drain tubing may get clots or clogs that may keep the fluid from draining. Before you empty and measure the fluid, you will need to clear the clots from the tubing each time. This is called “stripping or “milking” the tubing. **Follow these steps to clear the tubing.**

1. Wash your hands well with soap and warm water. Rinse and dry.
2. Using one hand, firmly hold the tubing near where it comes out of the skin. This will prevent the drain from being pulled out while you are stripping it.
3. Firmly pinch the tubing with your other hand, using your thumb and first (index) finger. Squeeze the tubing and slowly slide your fingers down the tubing toward the drain. Squeeze the tubing firm enough so it becomes flat. **Do not** use your fingernails as they may damage the tubing.

Daryeelidda Gooriyahaaga

- Waa inaad “duugtid” tuubada gororiyaha si aad uga saartid xinjiro ama wax fadhiistay tuubada dhexdeeda si gororiyuhu ugu shaqeeyo si fiican.
- Waxa aad u baahan doontaa inaad faaruqisid gororiyaha oo nadiifisid maqaarka ku wareegsan tuubada gororiyaha.
- Haddii gororiyahaagu leeyahay faashad, waxa lagu siin doonaa fariimo ku saabsan sida loo beddelo.

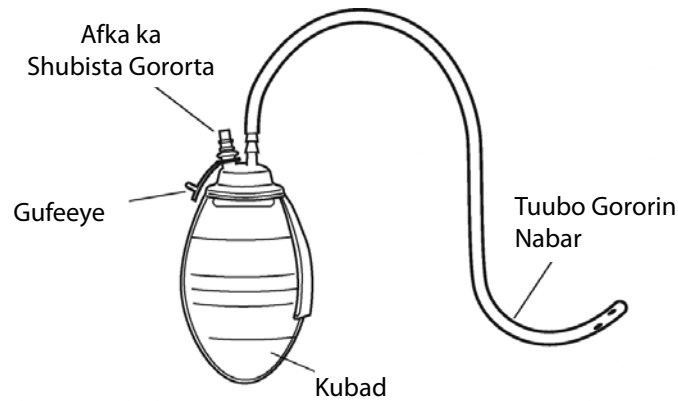

Sida Loo “Duugo” Tuubada Gororiyaha

Waxa laga yaabaa in tuubada gororiyaha ay ku joogsadaan xinjiro ama wax gufeeyaan oo dheecaanka ka hor joogsadaan inuu gororo. Ka hor inta aanad faaruqin oo cabirin dheecaanka, waxa aad u baahan doontaa inaad xinjiraha ka saartid tuubada wakhti kasta. Waxa tan loo yaqaanaa “duugidda” ama “lisidda” tuubada. **Raac tallaabooyinka si aad tuubada uga saartid waxa gufeynaya.**

1. Gacmahaaga si fiican ugu dhaq saabuun iyo biyo diiran. Biyo raaci oo qallaji.
2. Adiga oo isticmaalaya hal gacan, si xooga tuubada ka qabo meesha ay ka soo baxdo maqaarka. Tani waxay ka hortagi doontaa in gororiyaha dibadda u soo jiidmo marka aad duugaysid.
3. Gacantaada kale si xoogan ugu cadaadi tuubadada, adiga oo isticmaalaya suulkaaga iyo farta koowaad (murdisada). Tuuji tuubada oo si aayar ah tuujiska u sii wad xagga hoose illaa gororiyaha. Tuubada u tuuji si xoogan oo ku filan inay isku simanto ama dhinacyadu is taabtaan. **Ha isticmaalin** cidiyaha farahaaga sababta oo ah waxa laga yaabaa inay waxyeelaan tuubada.

Home Care Wound Drain. Somali.

4. If you see a clot, you may stop and start to move the clot through the tubing. You can use an alcohol pad around the tubing to make it easier to slide your fingers down the tubing.
5. **Stop** if you are pulling on the tubing so much that it hurts. You do not want to pull the tubing so hard that you pull it out of the skin.
6. When you reach the drain, let go of the tubing and remove your hand from the area from where the tubing comes out of your skin.
7. Repeat if needed.

How to Empty Your Drain

Empty your drain in the morning and again in the evening. You should also empty the drain any time it is heavy with a lot of fluid. To empty the drain follow these steps.

1. Wash your hands well with soap and warm water. Rinse and dry.
2. Get a measuring cup and the **Wound Drainage Record Sheet** included at the end of this handout. Use a record sheet to write down the amount and color of fluid from the drain.
3. Unfasten the pin or clip that holds the drain to your clothing.
4. Open the plug on the drain.
5. Turn the drain upside down over the measuring cup and gently squeeze the drain to empty it.
6. Continue to squeeze the drain. Press down on the drain until it is flat and replace the plug. All of the air needs to be out of the drain or it will not work properly.
7. If you are not able to squeeze and plug the drain at the same time, you can put the drain on a firm flat surface like a table.
8. Do not let the drain dangle. Carefully pin or clip the drain to your clothing. Attach the drain lower than the area where it comes out of your body. Make sure the tubing lies flat with no kinks.

4. Haddii aad aragtid xinjir, waad joogsan kartaa oo bilaabi kartaa inaad dhaqaajisid xinjirta gudaha tuubada. Waxa aad isticmaali kartaa suuf aalkolo leh oo aad ku qabatid dusha tuubada si ay kuugu fududaato inaad farahaaga silbisid illaa xagga hoose ee tuubada.
5. **Joogso** haddii aad si xoogan u soo jiidaysid tuubadda oo aad dareentid xanuun. Tuubada ha u soo jiidin si xoog badan oo keenaysa inay ka soo baxdo maqaarkaaga.
6. Marka aad gaahid gororiyaha, sii daa tuubada oo ka qaad gacantaada aagga ay tuubadu ka soo baxdo maqaarkaaga.
7. Ku Celi haddii loo baahdo.

Sida Loo Faaruqiyo Gororiyahaaga

Faaruuqi gororiyahaaga subixii iyo markale fidkii. Sidoo kale waa inaad faaruqisid gororiyaha wakhti kasta oo uu la culus yahay dheecaan badan. Si aad u faaruqisid gororiyaha raac talaabooyinkan soo socda.

1. Gacmahaaga si fiican ugu dhaq saabuun iyo biyo diiran. Biyo raaci oo qallaji.
2. Soo qaado koob cabiris iyo **Warqadda Diiwaangalinta Gororka** ee ku jirta dhammaadka qoraalkan. Istimaal warqadda diiwaangalinta si aad u qortid qaddarka iyo midabka dheecaanka ku jiray gororiyaha.
3. Fur biinka ama xejiyaha maradaada ku hayay gororiyaha.
4. Fur gufeeyaha saaran gororiyaha.
5. Gororiyaha ku dul foorari koobka cabirista oo si aayar ah u tuuji gororiyaha si aad u faaruqisid.
6. Sii wad inaad tuujisid gororiyaha. Sii cadaadi gororiyaha illaa uu isku sinmayo ka dibna gali gufeeyaha. Dhammaan hawada waa in laga saaro gororiyaha haddii kale si fiican uma shaqeyn doono.
7. Haddii aanad awoodin inaad isku wakhti tuujisid oo gufeysid gororiyaha, waxa aad gororiyaha saari kartaa oogo isku siman oo adag sida miis.
8. Ha oggolaan in gororiyuhu laadlaado. Si taxadir leh ugu qabo biin ama xejiye haysta maradaada. Ku qabo xejiyaha meel ka hooseysa meesha ay tuubadu dibadda uga soo baxo jidhkaaga. U hubso in tuubadu toosan tahay oo aanay isku marnayn ama murgin.

9. Check the amount and color of the fluid in the measuring cup. Call your doctor if the fluid is cloudy, bad smelling or the amount has increased.
10. Write the date, time, amount and color of the fluid on the wound drainage record sheet. If you have more than one drain, empty, measure and write down the amount of fluid for each drain.
11. Empty the fluid into the toilet, rinse the measuring cup and flush the toilet.
12. Wash your hands well with soap and warm water. Rinse and dry.

How to Clean the Skin Around Your Drain Tubing

1. You should clean the skin around your drain tubing once a day.
2. Wash your hands well with soap and warm water. Rinse and dry.
3. Clean the skin as directed by your doctor. The nurse will put a check (✓) in the box by what you need to use.
 - Soap and water
 - Other _____
4. Clean the skin around the tubing. Start at the center where the tube comes out of the skin. Use a circular motion to clean the skin around the tube. Slowly move out and away from the tube 3 to 4 inches. **Do not** clean back towards the tube. Let the skin dry.
5. Check the skin around the tube for any redness, swelling, warmth or a bad smelling drainage.
6. If you have more than one drain, clean the skin around each drain tube.
7. Wash your hands well with soap and warm water. Rinse and dry.

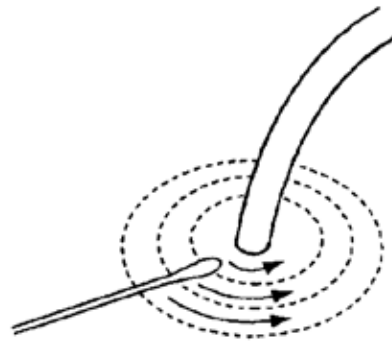

9. Fiiri qaddarka iyo midabka dheecaanka ku jira koobka cabirista. Wac dhakhtarkaaga haddii dheecaanku aanuu saafi ahayn, ur xun leeyahay ama qaddarku soo kordhay.
10. Warqadda diiwaangalinta gororka nabarka ku qor taariikhda, wakhtiga, qaddarka iyo midabka. Haddii uu kugu jiro wax ka badan hal gororiye, gororiye kasta faaruqi, cabir oo u qor qadarka dheecaan.
11. Dheecaanka ku shub musqusha, biyo raaci koobka cabirista oo biyaha ku sii daa musqusha.
12. Gacmahaaga si fiican ugu dhaq saabuun iyo biyo diiran. Biyo raaci oo qallaji.

Sida Loo Nadiifiyo Maqaarka ku Wareegsan Tuubada Gororinta

1. Waa inaad hal mar maalintii nadiifisid maqaarka ku wareegsan tuubada qororinta.
2. Gacmahaaga si fiican ugu dhaq saabuun iyo biyo diiran. Biyo raaci oo qallaji.
3. Maqaarka u nadiifi sida uu kuu tilmaamay dhakhtarkaagu. Kalkaalisada ayaa sax (✓) saari doonta sanquuda waxa aad u baahan tahay inaad isticmaashid.
 - Saabuun iyo biyo
 - Wax kale _____
4. Nadiifi maqaarka ku wareegsan tuubada. Ka bilaw dhexda meesha tuubadu ka soo baxdo maqaarka. Samee dhaqaaq wareeg ah si aad u nadiifisid maqaarka ku wareegsan tuubada. Si aayar ah dibadda u dhaqaaq oo ka sii fogow tuubada 3 illaa 4 inji. **Dib ha** ugu soo nadiifin xagga tuubada. Daa ha qallalo maqaarku.
5. Maqaarka ku wareegsan tuubada ka fiiri casaan, barar, diirimaad ama dheecaan leh ur xun.
6. Haddii uu kugu jiro wax ka badan hal gororiye, nadiifi maqaarka ku wareegsan tuubada gororiye kasta.
7. Gacmahaaga si fiican ugu dhaq saabuun iyo biyo diiran. Biyo raaci oo qallaji.

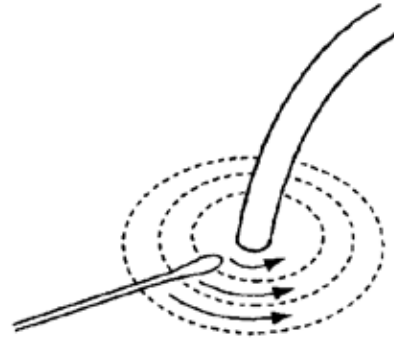

How to Change the Dressing

If you have a dressing, you need to change it once a day or if the dressing gets wet or dirty. **Follow these directions for how to change the dressing:**

1. Gather your supplies and set up a clean work area.
2. Wash your hands well with soap and warm water. Rinse and dry.
3. Loosen the tape and remove the old dressing. Be careful not to pull the drain out. Look at the dressing for any unusual or bad smelling drainage. Put the old dressing in a plastic bag and throw it away in the trash.
4. Wash your hands again with soap and warm water. Rinse and dry.
5. Check the skin around the tubing for any redness, swelling, warmth or bad smelling drainage.
6. Clean the skin around your tubing. **Follow the instructions on page 4, “How to Clean the Skin Around Your Drain Tubing”.**
7. Use tape to secure the dressing.
8. Open the 4 x 4 split gauze dressing package and remove the gauze pad. Touch **only** the edges of the gauze pad. Put the gauze around the tube as shown in the picture.

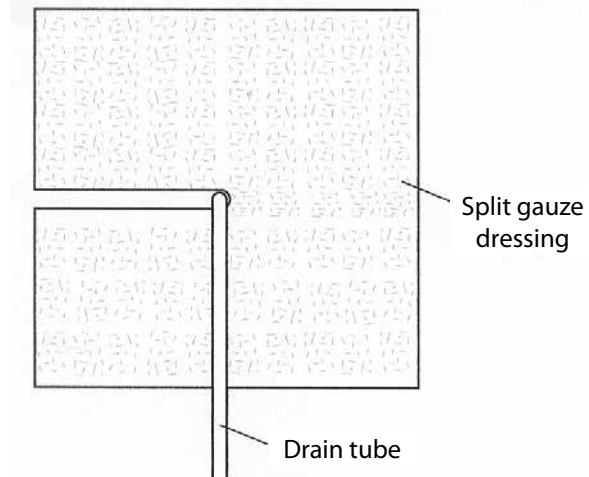

Sida Loo Beddelo Faashadda

Haddii ay ku saaran tahay faashad, waa inaad beddeshid mal mar maalintii ama haddii faashadu qoydo ama wasakh noqoto. **Raac fariimahan ku saabsan sida loo beddelo faashadda:**

1. Meel isugu keen alaabtaada oo go'aami aag shaqo oo nadiifi ah.
2. Gacmahaaga si fiican ugu dhaq saabuun iyo biyo diiran. Biyo raaci oo qallaji.
3. Dabci dhejiska oo meesha ka qaad faashaddii hore. Ka taxadir in aanad dibadda u soo jeedin gororiyaha. Faashadda ka fiiri dheecaan aan caadi ahayn ama leh ur xun. Faashaddii hore ku rid bac oo ku tuur qashinka.
4. Gacmahaaga si fiican ugu dhaq saabuun iyo biyo diiran. Biyo raaci oo qallaji.
5. Maqaarka ku wareegsan tuubada ka fiiri casaan, barar, diirimaad ama dheecaan leh ur xun.
6. Nadiifi maqaarka ku wareegsan tuubadaada. **Raac fariimaha ku yaala bogga 4, "Sida Loo Nadiifiyo Maqaarka ku Wareegsan Tuubadaada Gororinta".**
7. Isticmaal dhejis si meesha loogu xejiyo faashadda.
8. Fur xidhmada faashadda daldaloosha ee jeexan ee ah 4 x 4 oo soo saar faashadda. Taabo **kaliya** cidhifyada faashadda. Sida lagugu tusayo sawirka faashadda u saar agagaarka tuubada.

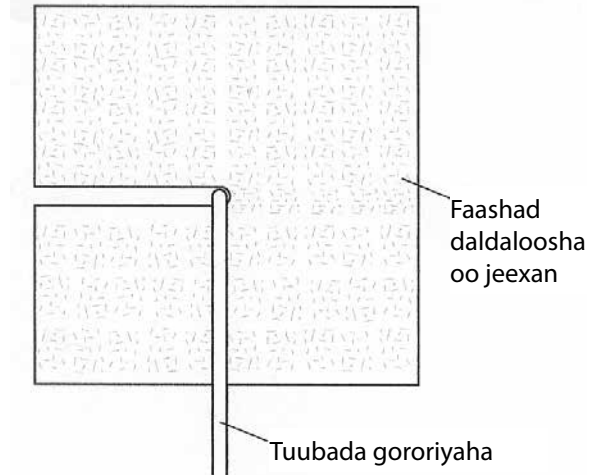

9. If you are directed to use a second split gauze dressing, place it over the first gauze dressing. Place the second gauze to cover the tube as shown in the picture.

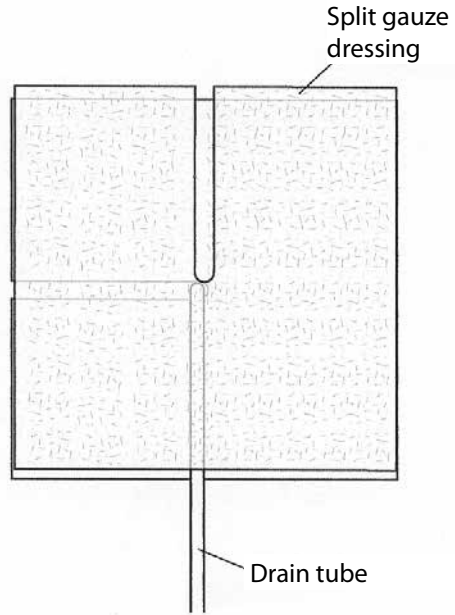

10. Tape the dressing in place. If you are to cover the whole dressing, use 3 pieces of tape. Put the first piece of tape where the tube comes out from under the dressing. Pinch the tape around the tube so it will not move if it gets pulled.

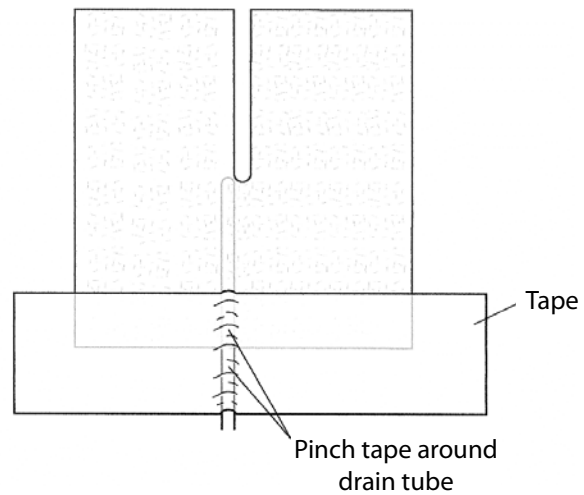

11. Put the second piece of tape over the center of the dressing so the edges of the tapes just overlap.

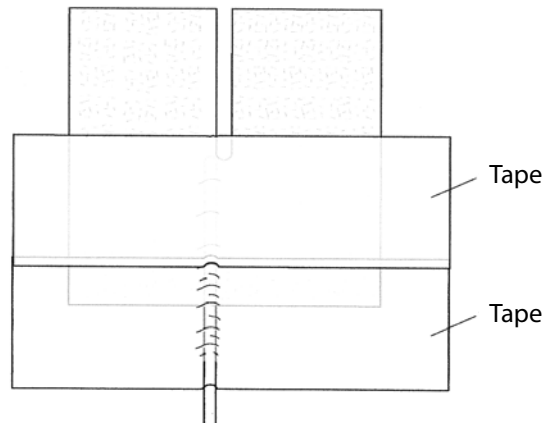

9. Haddii lagu sheego inaad isticmaashid faashad daldaloosha oo jeexan oo labaad, dul saar faashadda daldaloosha ee koowaad. Faashadda labaad u dul saar tuubada sida lagu muujiyay sawirka.

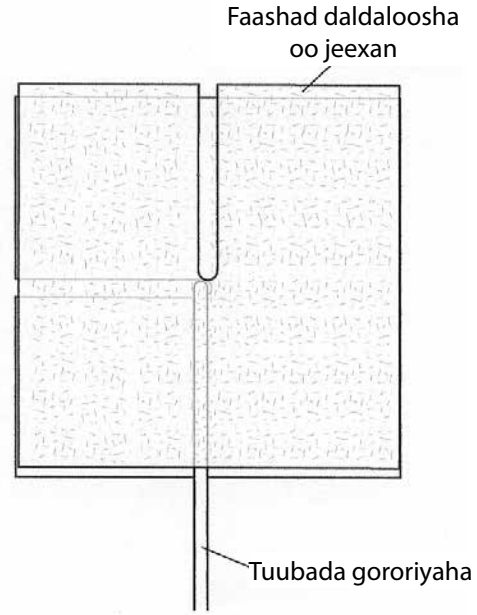

10. Faashadda meesha ku dheji adigoo isticmaala dhejis. Haddii aad daboolaysid faashadda oo dhan, isticmaal 3 qaybood oo ah dhejis. Qaybta koowaad ee dhejiska saar meesha tuubadu ka soo hoos baxdo faashadda. Ku cadaadi dhejiska hareeraha tuubada si aanay u dhaqaaqin haddii la soo jiido.

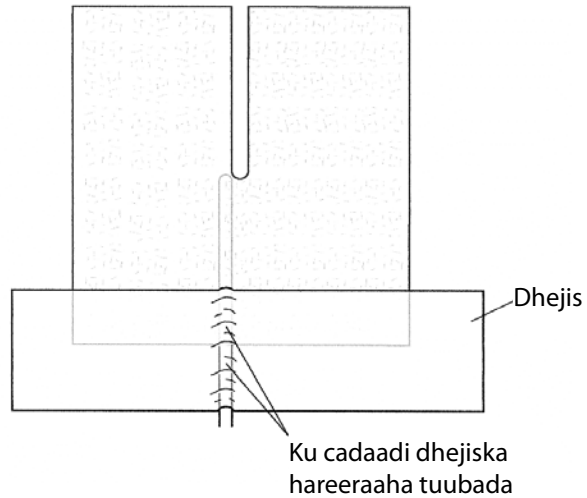

11. Qaybta labaad ee dhejiska saar dhexda faashadda si cidhifyada dhejisyadu isku dhaafaan.

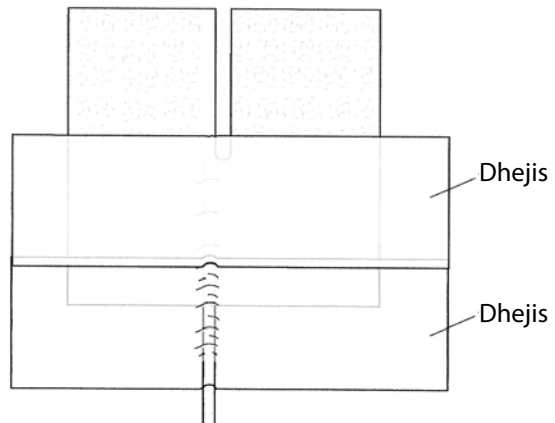

12. Then put a third piece of tape to cover the rest of the dressing.

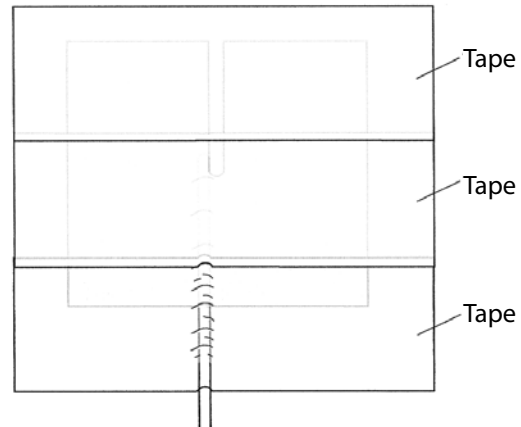

When to call the doctor?

Call your doctor **right away** if you have any of the following:

- Fever of 100.4 degrees Fahrenheit (38 degrees Celsius) or higher
- Redness, swelling, or unusual drainage where the tube comes out of the skin
- Drainage that becomes milky, cloudy or bad smelling
- A sudden increase in the amount of drainage (more than 40 ml's)
- Any new or increased pain
- Clots or clogs in the tubing that you are unable to clear by stripping
- Little or no drainage in the drain and fluid is leaking where the tube comes out of the skin
- Your drain will not stay pressed together after you have emptied it
- The drain tubing pulls out of your skin
- Skin irritation, redness or blistering from the tape over your dressing

10/2013 Health Information Translations

Unless otherwise stated, user may print or download information from www.healthinfotranslations.org for personal, non-commercial use only. The medical information found on this website should not be used in place of a consultation with your doctor or other health care provider. You should always seek the advice of your doctor or other qualified health care provider before you start or stop any treatment or with any questions you may have about a medical condition. The Ohio State University Wexner Medical Center, Mount Carmel Health System, OhioHealth and Nationwide Children's are not responsible for injuries or damages you may incur as a result of your stopping medical treatment or your failure to obtain medical treatment.

12. Ka dibna qaybta saddexaad ee dhejiska saar inta hadhay ee faashadda.

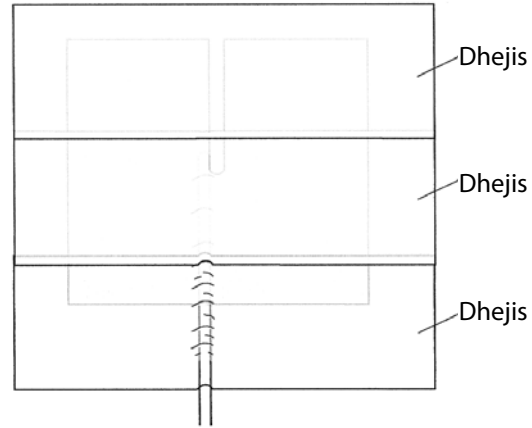

Goorta la waco dhakhtarka?

Wac dhakhtarkaaga **isla markiiba haddii** aad leedahay mid ka mid ah kuwan soo socda:

- Qandho ah 100.4 darajo Fahrenhayt (38 darajo Selsiyas) ama ka sareeya
- Casaan, barar, ama dheecaan aan caadi ahayn oo ah meesha tuubadu ka soo baxdo maqaarka
- Dheecaan noqda caano oo kale, aan saafi ahayn ama ur xun leh
- Korodh dhakhso ah oo ku yimaada qaddarka gororka (in ka badan 40 ml)
- Xanuun cusub ama soo kordhay
- Xinjiro ama gufeysan ku jira tuubada oo aanad faaruqin karin inta aad duugtid
- Dheecaanka gororiyaha oo yar ama jirin iyo dheecaan ka imana meesha ay tuubadu ka soo baxdo maqaarka
- Gororiyahaagu iskuma sii cadaadisnaanayo ka dib marka aad faaruqisid
- Tuubada gororiyaha ayaa dibadda uga soo baxday maqaarkaaga
- Xajiin maqaar, casaan ama finan biyo leh oo ka imanaya dhejiska dul saaran faashaddaada

10/2013 Health Information Translations

Unless otherwise stated, user may print or download information from www.healthinfotranslations.org for personal, non-commercial use only. The medical information found on this website should not be used in place of a consultation with your doctor or other health care provider. You should always seek the advice of your doctor or other qualified health care provider before you start or stop any treatment or with any questions you may have about a medical condition. The Ohio State University Wexner Medical Center, Mount Carmel Health System, OhioHealth and Nationwide Children's are not responsible for injuries or damages you may incur as a result of your stopping medical treatment or your failure to obtain medical treatment.

Home Care Wound Drain. Somali.

Wound Drainage Record Sheet

Write in the date, time, amount and color of the fluid from each drain every time you empty a drain.

Goror = drain

midab = color

qaddar = amount

dheecaan = fluid

Date	Drain # _____ Amount and color of fluid		Drain # _____ Amount and color of fluid	
	AM	PM	AM	PM
	_____ml color:	_____ml color:	_____ml color:	_____ml color:
	_____ml color:	_____ml color:	_____ml color:	_____ml color:
	_____ml color:	_____ml color:	_____ml color:	_____ml color:
	_____ml color:	_____ml color:	_____ml color:	_____ml color:
	_____ml color:	_____ml color:	_____ml color:	_____ml color:
	_____ml color:	_____ml color:	_____ml color:	_____ml color:
	_____ml color:	_____ml color:	_____ml color:	_____ml color:
	_____ml color:	_____ml color:	_____ml color:	_____ml color:
	_____ml color:	_____ml color:	_____ml color:	_____ml color:
	_____ml color:	_____ml color:	_____ml color:	_____ml color:
	_____ml color:	_____ml color:	_____ml color:	_____ml color:

Warqadda Diiwaangalinta Gororka

Qor taariikhda, wakhtiga, qaddarka iyo midabka dheecaanka ee goror kasta wakhti kasta oo aad faaruqisid gororiyaha.

Goror = drain

midab = color

qaddar = amount

dheecaan = fluid

Taariikh	Goror # _____ Qaddar iyo midab dheecaan		Goror # _____ Qaddar iyo midab dheecaan	
	Galin Hore	Galin Dambe	Galin Hore	Galin Dambe
	_____ml midab:	_____ml midab:	_____ml midab:	_____ml midab:
_____ml midab:	_____ml midab:	_____ml midab:	_____ml midab:	
_____ml midab:	_____ml midab:	_____ml midab:	_____ml midab:	
_____ml midab:	_____ml midab:	_____ml midab:	_____ml midab:	
_____ml midab:	_____ml midab:	_____ml midab:	_____ml midab:	
_____ml midab:	_____ml midab:	_____ml midab:	_____ml midab:	
_____ml midab:	_____ml midab:	_____ml midab:	_____ml midab:	
_____ml midab:	_____ml midab:	_____ml midab:	_____ml midab:	
_____ml midab:	_____ml midab:	_____ml midab:	_____ml midab:	
_____ml midab:	_____ml midab:	_____ml midab:	_____ml midab:	
_____ml midab:	_____ml midab:	_____ml midab:	_____ml midab:	

Date	Drain # _____		Drain # _____	
	Amount and color of fluid		Amount and color of fluid	
	AM	PM	AM	PM
	_____ml color:	_____ml color:	_____ml color:	_____ml color:
	_____ml color:	_____ml color:	_____ml color:	_____ml color:
	_____ml color:	_____ml color:	_____ml color:	_____ml color:
	_____ml color:	_____ml color:	_____ml color:	_____ml color:
	_____ml color:	_____ml color:	_____ml color:	_____ml color:
	_____ml color:	_____ml color:	_____ml color:	_____ml color:
	_____ml color:	_____ml color:	_____ml color:	_____ml color:
	_____ml color:	_____ml color:	_____ml color:	_____ml color:
	_____ml color:	_____ml color:	_____ml color:	_____ml color:
	_____ml color:	_____ml color:	_____ml color:	_____ml color:
	_____ml color:	_____ml color:	_____ml color:	_____ml color:
	_____ml color:	_____ml color:	_____ml color:	_____ml color:
	_____ml color:	_____ml color:	_____ml color:	_____ml color:
	_____ml color:	_____ml color:	_____ml color:	_____ml color:
	_____ml color:	_____ml color:	_____ml color:	_____ml color:
	_____ml color:	_____ml color:	_____ml color:	_____ml color:
	_____ml color:	_____ml color:	_____ml color:	_____ml color:
	_____ml color:	_____ml color:	_____ml color:	_____ml color:

Taariikh	Goror # _____ Qaddar iyo midab dheecaan		Goror # _____ Qaddar iyo midab dheecaan	
	Galin Hore	Galin Dambe	Galin Hore	Galin Dambe
	_____ml midab:	_____ml midab:	_____ml midab:	_____ml midab:
_____ml midab:	_____ml midab:	_____ml midab:	_____ml midab:	
_____ml midab:	_____ml midab:	_____ml midab:	_____ml midab:	
_____ml midab:	_____ml midab:	_____ml midab:	_____ml midab:	
_____ml midab:	_____ml midab:	_____ml midab:	_____ml midab:	
_____ml midab:	_____ml midab:	_____ml midab:	_____ml midab:	
_____ml midab:	_____ml midab:	_____ml midab:	_____ml midab:	
_____ml midab:	_____ml midab:	_____ml midab:	_____ml midab:	
_____ml midab:	_____ml midab:	_____ml midab:	_____ml midab:	
_____ml midab:	_____ml midab:	_____ml midab:	_____ml midab:	
_____ml midab:	_____ml midab:	_____ml midab:	_____ml midab:	
_____ml midab:	_____ml midab:	_____ml midab:	_____ml midab:	
_____ml midab:	_____ml midab:	_____ml midab:	_____ml midab:	
_____ml midab:	_____ml midab:	_____ml midab:	_____ml midab:	
_____ml midab:	_____ml midab:	_____ml midab:	_____ml midab:	
_____ml midab:	_____ml midab:	_____ml midab:	_____ml midab:	
_____ml midab:	_____ml midab:	_____ml midab:	_____ml midab:	
_____ml midab:	_____ml midab:	_____ml midab:	_____ml midab:	
_____ml midab:	_____ml midab:	_____ml midab:	_____ml midab:	

Home Care Wound Drain. Somali.